

# somat®

## Remote Waste Pulping System



### Description

Standard SOMAT Model D-7-1/2 table mounted disposer, 18" stainless steel diameter bowl with disposer saver, 3 or 5 HP slurry pump, valve package, Som-A-Trol® control panel, push button station

#### Benefits

- Up to 80% volume reduction
- Reduced labor cost
- Better sanitation
- Water conservation
- Improved operator morale

**Operation:** Foodservice waste enters the disposer via the bowl where it mixes with water, is processed and made into a slurry. The slurry, consisting of 5% solids and 95% water, is automatically transported through a pipeline to the Hydra-Extractor®, where water is removed and the resultant semi-dry pulp is discharged into a haul-away container. The extracted water is recovered and returned to the pulping tank for re-use.

Somat equipment provides an economic and efficient answer to cutting the high and ever increasing costs associated with waste handling. Manufactured by Somat Company of Lancaster, Pennsylvania, originators of waste pulping systems and specialists in waste reduction technology.

#### Approval:

6/14/05

Item No \_\_\_\_\_

SOMAT Model: **D-7-1/2 Disposer**

### Technical Specifications

**Disposer:** 7-1/2 HP disposer, 10-5/8" diameter rotor turntable with exclusive adjustable 45 degree angle and 6 internal impact breakers constructed of hardened ductile steel alloy. Matching 45 degree sizing ring with 24 grind teeth constructed of hardened ductile steel alloy. Exclusive 8 1/4" throat opening to allow for faster feeding. Flexible neoprene collar to eliminate vibration and increase ease of installation. Versatile low body of offset grind chambers with force feed directional deflectors. Bolt on grind chamber allows replacement of all wearing parts without disturbing plumbing and electrical connections. Bolt on discharge flange for easy removal. Adjustable legs to level disposer and meet drain stub. Bolt on "Continuous Duty" motor for easy removal. Exclusive shaft extension with 3/4" wrench flats to externally de-jam foreign matter with special tools. Heavy cast alloy construction providing an extra long life disposer

**Valve Package:** Piped valve package assemblies to include all valves required for proper operation.

**Som-A-Trol® (Electrical Control Panel):** UL approved, Includes all necessary power, control and water level components prewired to a terminal strip. Push button station in a NEMA 4 stainless steel enclosure

#### Options Available:

- 8 1/4" sink adapter with disposer saver
- Special electrical characteristics

**Electrical Characteristics:** 208/230/460 volt, 3 Phase, 60 Hertz

**Capacity:** 500 pounds per hour of food waste only.

**Finish:** All exterior surfaces, except where polished stainless steel, are prime coated and finished with two coats of enamel paint.

Equipment only is supplied by SOMAT Company; installation, piping and wiring not included.



Somat Company  
Division of ITW Food Equipment Group LLC  
165 Independence Court  
Lancaster, PA 17601 USA  
Tel: 717-397-5100 Fax: 717-291-0877  
1-800-237-6628  
[www.somatcompany.com](http://www.somatcompany.com)

# somat®

## Remote Waste Pulping System

### SOMAT Model: D-7-1/2 Disposer

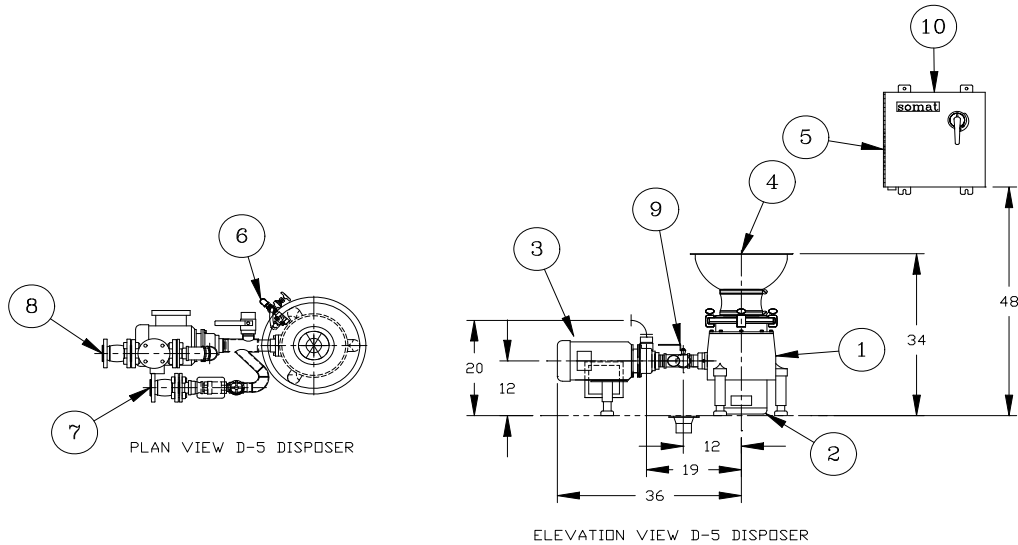

Utility rough-ins may vary with final configuration.  
Return & slurry piping assemblies not shown  
Unit shown with 3 hp slurry pump  
**Enlarge drawing by 129% to achieve 1/2" scale**  
**Reduce drawing by 64% to achieve 1/4" scale.**  
**A complete CAD library is now available.**

## Somat® Model D-10 Disposer:

- |                                 |  |
|---------------------------------|--|
| 1. D-7-1/2 Disposer             | 4. 18" dia. Bowl w/disposer saver, return water flushed          |
| 2. Disposer drive motor, 7.5 hp | 5. Som-A-Trol panel (20"h x 16"w x 8"d) with push button station |
| 3. Slurry pump, 3 hp or 5 hp    |  |

### Utility Connections:

- |                                |   |
|--------------------------------|---|
| 6. Fresh water inlet, 1/2" npt | 9. Drain valve, 2" npt                              |
| 7. Return water inlet, 2" npt  | 10. Customer power supply (4 wire service required) |
| 8. Slurry pump outlet, 2" npt  |   |

### Dimensions:

Height: 34" (865 mm)	Equipment Weight/Operating Weight: 375 lbs.
Length: 46 (1150 mm)	Crated Weight: 525 lbs.
Width: 22" (560 mm)	Crated volume: 85 cu. ft.

### Utility Requirements:

Fresh water: 4 gpm @ 30 psig, 1/2" NPT (approximate usage 240 gph).  
Drain: 3" minimum floor sink, with stainless steel removable basket recommended.  
Power: 208V - 50 amps; 230V - 50 amps; 460V - 25 amps, 3 phase, 60 Hz. (w/5 HP slurry pump)  
(disconnect with circuit breaker provided in Som-A-Trol)

TRADEMARK NOTICE: SOMAT, HYDRA EXTRACTOR, SOM-A-TROL, SOM-A-PRESS, SOM-A-SYSTEM are registered trademarks of Somat Company.

SOMAT reserves the right to change specifications without notice.  
6/14/05

**Somat Company**

Division of ITW Food Equipment Group LLC  
165 Independence Court  
Lancaster, PA 17601 USA  
Tel: 717-397-5100 800-237-6628  
Fax: 717-291-0877  
www.somatcompany.com