

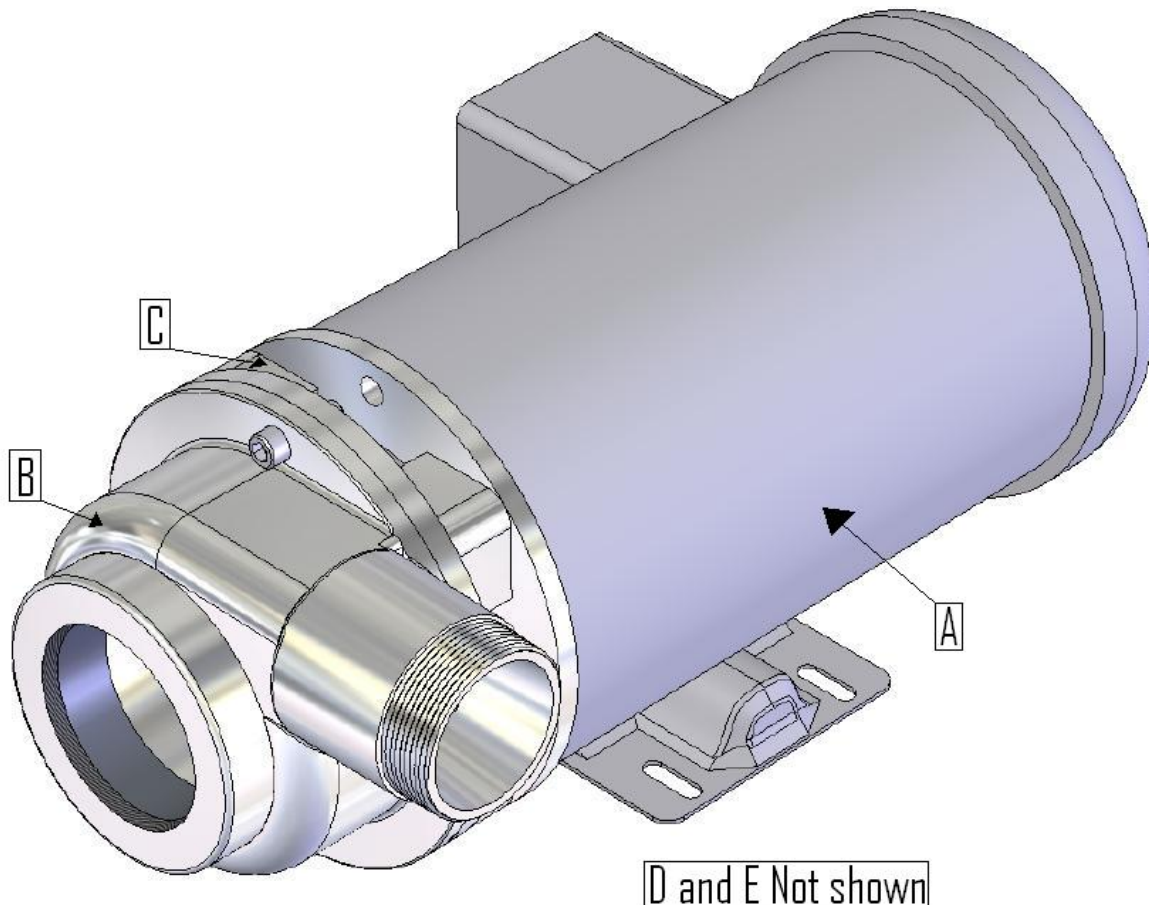

## KW DIRECT DRIVE PUMP

### DESCRIPTION

**GENERAL** - The K/W Pump is a direct drive, end suction centrifugal pump. The pump is driven by a C-face electric motor; see Figure 1 (A) which also acts as the pump base. The pump housing (B) mounts on a spacer ring (C) which in turn is mounted to the face of the motor and becomes an integral part of the motor frame. An open type impeller (D) is used to minimize clogging. The pump housing is provided with a mechanical seal (E) to prevent leakage from the pump housing into the motor frame.



**Figure 1. K/W Pump - General Arrangement**

## MAINTENANCE

**PERIODIC MAINTENANCE AND INSPECTION** - These procedures consist primarily of regularly scheduled cleaning and inspections. The time intervals cited are based on normal use of the SOMAT<sup>®</sup> unit; approximately **six hours per day**, seven days per week. Equipment operating more than this or in severe service will require more frequent inspection/maintenance.

Since the Drive Motor is a permanently lubricated, sealed unit, lubrication instructions will be considered not applicable.

Particular attention should be paid to impeller wear and seal leakage since this will affect the performance of the pump. Continued adherence to these inspections will provide adequate lead time when ordering spare parts, thereby minimizing unnecessary and costly equipment downtime.

## INSPECTION SCHEDULE

	DAILY	WEEKLY	MONTHLY	QUARTERLY
<b>1. GENERAL</b>				
a. Check exterior finish for corrosion				X
b. Check pump casing for wear				X
c. Check impeller for wear				X
<b>2. DRIVE</b>				
a. Check seals for leakage	X			
b. Check bearings for noise and wear				X

## TROUBLESHOOTING AND ANALYSIS FOR GENERAL SYSTEM

The following table provides probable causes and appropriate corrective action relative to pump malfunctions. When corrective action requires part or component replacement or a specific adjustment procedure, refer to the applicable part of this section.

SYMPTOM	POSSIBLE CAUSE	CORRECTIVE ACTION
No water delivered	<ol style="list-style-type: none"> <li>1. Impeller worn or clogged.</li> <li>2. Clogged lines</li> </ol>	<ol style="list-style-type: none"> <li>1. Check impeller, clean or replace as required.</li> <li>2. Check individual cleanouts for loss of pressure to locate blockage. Remove blockage.</li> </ol>
Seal Leaking	<ol style="list-style-type: none"> <li>1. Worn or damaged seal or motor</li> </ol>	<ol style="list-style-type: none"> <li>1. Check seal and motor shaft. Replace as required.</li> </ol>

**COMPONENT REMOVAL AND REPLACEMENT** - The following steps are required in the removal and replacement of major components, assemblies or piece parts, necessary for corrective action.



### IMPELLER REMOVAL -

- Remove four screws (2) from pump housing (1).
- Separate pump housing from spacer ring (9).
- Lift "O" Ring (3) from groove in spacer ring.
- Remove the 10-32 x 5/8 long screw (6) from the end of the motor shaft (12).
- Remove impeller from motor shaft. (A gear puller may be required to remove impeller).
- Remove key (8) from motor shaft.
- Replace the impeller by placing it over the motor shaft with the keyways of the shaft and the impeller hub aligned. Tap the key in place using a lead or rawhide mallet. Replace socket head cap screw.

## **TROUBLESHOOTING AND ANALYSIS FOR KW PUMP**

### **MECHANICAL SEAL REMOVAL & REPLACEMENT -**

- Perform all steps for impeller removal.
- Remove the four 3/8-16 X 1-3/4 long socket head cap screws (10) and remove the pump spacer ring (9) from the face of the drive motor (12).
- Tap the ceramic seal ring from the seal retaining ring using a strip of wood for a punch.
- Remove all pieces from the seal cavity and wipe the cavity clean with soapy water and a suitable wiping material.
- Remove the retainer spring and seal ring from drive motor shaft.
  
- When replacing the seal ring, moisten the O-Ring of the ceramic seal with soapy water. Using a strip of wood for a punch, gently tap the ceramic seal ring into place and seat it squarely into the recess in the pump spacer ring.
- Slip the retainer spring over the motor shaft.
- Lubricate the upper seal ring and slip it over the motor shaft. Be certain the carbon portion of the ring faces away from the motor, and the opposite side engages the retainer spring.
- Slip the pump spacer ring with the ceramic seal ring installed over the motor shaft and seat on surface of drive motor.
- Replace four screws to complete the reassembly.

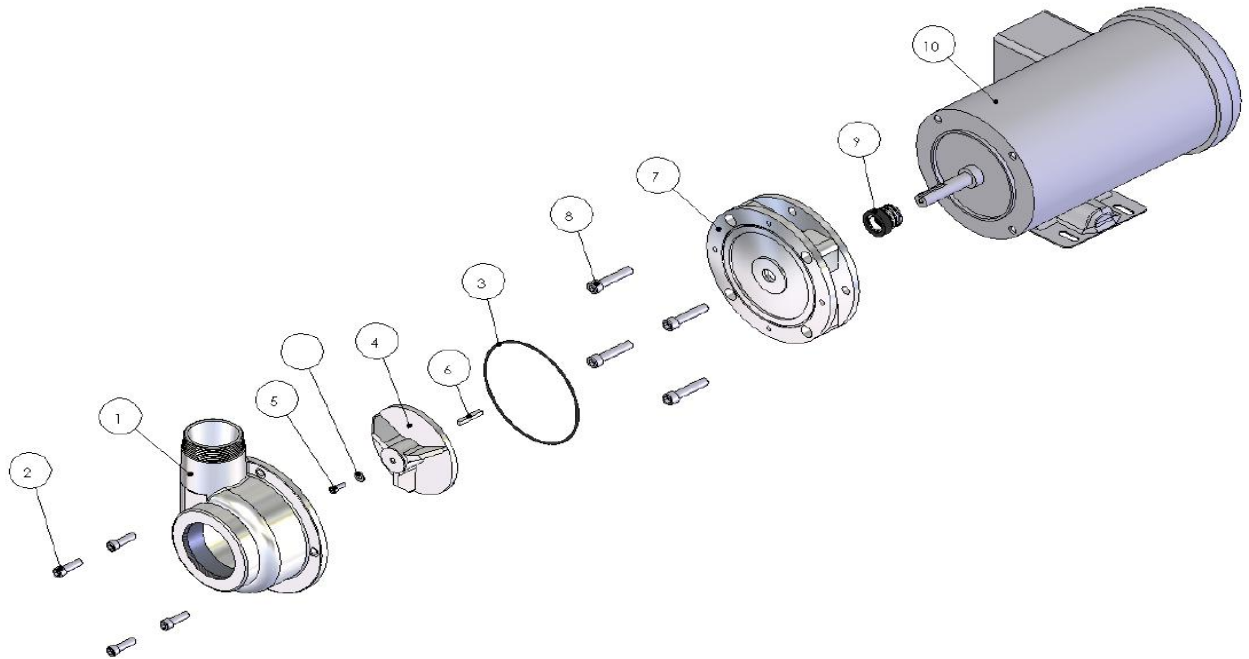

**FIGURE 2. KW DIRECT DRIVE PUMP EXPLODED VIEW**

**FIG AND  
INDEX NO.  
REQ.**

**DESCRIPTION**

2-	<b><i>PUMP ASSEMBLY, K/W DIRECT DRIVE</i></b>	
-1	Housing, Pump (83200-2) (ATTACHING PARTS)	1
-2	Screw, Socket Head, 5/16-18 x 3/4" Lg. ---*---	4
-3	"O" Ring (45700)	1
-4	Impeller, 2HP (84153-2), 3HP (84152-2), 5HP (84151-2) (ATTACHING PARTS)	1*
-5	Screw, Socket Head, #10-32 x 5/8" Lg.	1
-6	Key, 3/16 x 3/16 x 1-1/8" Lg. ---*---	1
-7	Ring, Spacer, 2HP and 3HP (86300-2), 5HP ( 86301-2) (ATTACHING PARTS)	1
-8	Screw, Socket Head, 3/8-16 x 1-3/4" Lg. ---*---	4
-9a	Seal, Mechanical, 5/8" 2HP and 3HP (54300)	1*
-9b	Seal, Mechanical, 7/8" 5HP (54302)	1*
-10a	Motor, 2HP (41640)	1
-10b	Motor, 3HP (41652)	1
-10c	Motor, 5HP (41708)	1

\* Recommended Spare Parts