

FIGURE 2. HYDRA EXTRACTOR[®], MODEL HE-6S-3, EXPLODED VIEW

FIG & INDEX NO.	DESCRIPTION	REQ.
2-	HYDRA-EXTRACTOR[®], MODEL HE-6S-3	
-1	Drive Motor 3 HP (41670) (ATTACHING PARTS)	1
-2	Key, 3/16" X 3/16" X 1-5/8" Lg.	1
-3	Bolt, Hex Head, Cad Pl., 3/8-16 X 3/4" Lg.	4
-4	Washer, Lock, Cad Pl., 3/8" ID	4
	---*---	
-5	Reducer 3 HP (51689-3) (ATTACHING PARTS)	1
-6	Bolt, Hex Head, Cad Pl., 3/8-16 X 2-3/4" Lg.	1
-7	Washer, Flat, 3/8" ID X 2" OD (89200)	1
-8	Screw, Machine, Hex Head, Cad Pl., 3/8-16 X 1-1/4" Lg.	4
-9	Washer, Lock, Cad Pl., 3/8" ID	4
-10	Nut, Hex, Cad Pl., 3/8-16 (ATTACHING PARTS)	4
	---*---	
-11	Head Assembly, S/S (89370) (ATTACHING PARTS)	1
-12	Screw, Hex Head, 5/16-18 X 1/2" Lg., S/S	4
-13	Washer, Lock, 5/16" ID, S/S	4
-14	Nut, Hex, Cad Pl., 3/8-16 (ATTACHING PARTS)	4
	---*---	
-15	Screen Assembly (54005) (ATTACHING PARTS)	1*
-16	Screw, Button Head, Socket Type, 5/16-18 X 1" Lg., S/S	2
-17	Washer, Lock, 5/16" ID, Split Type, S/S	2
-18	Nut, Hex, 5/16-18, S/S (ATTACHING PARTS)	2
	---*---	
-19	Screw Assembly, Extractor (86820)	1*
-20	Brush, Nylon (16000)	1
-21	Key, 3/8" X 3/8" X 3" Lg. (ATTACHING PARTS)	1
-22	Screw, Machine, Hex Head, 3/8-16 X 1-1/2" Lg., S/S	4
-23	Washer, Lock, 3/8" Split Type, S/S	4
-24	Nut, Hex, 3/8-16, S/S (ATTACHING PARTS)	4
	---*---	
-25	Bushing, Lower, Screw Shaft (81350)	1*
-26	Shell Weldment (89370)	1
-27	Cover, Access (80015)	1
-28	Handle, Aluminum (35220) (ATTACHING PARTS)	1
-29	Screw, Round Head, #10-32 X 1/2" Lg., S/S	2
-30	Washer, Lock, #10 Split Type, S/S (ATTACHING PARTS)	2
	---*---	

-31	Pin, Bottom, S/S (81055)	1*
-----	--------------------------	----

FIG & INDEX NO.	DESCRIPTION	REQ.
-32	Gasket, Bottom Pin (82786)	1
-33	Bottom Pin Plate (81025)	1
	(ATTACHING PARTS)	
-34	Washer, Flat, 1/2" ID, Cad Pl.	1
-35	Screw, Hex Head, Machine, 1/2-13 X 1" Lg., Cad Pl.	1
-36	Screw, Hex Head, 3/8-16 X 1" Lg., Cad Pl.	6
-37	Washer, Flat, 3/8" ID, Cad Pl.	6
-38	Nut, Hex, 3/8-16, Cad Pl.	6
	---*---	
-39	Discharge Chute (81531)	1
	(ATTACHING PARTS)	
-40	Screw, Round, #10-32 X 3/4" Lg., S/S	2
-41	Nut, Hex, #10-32, S/S, Elastic Stop	2
	---*---	
-42	Magnetic Switch (54999-1)	1
	(ATTACHING PARTS)	
-43	High Energy Magnet (55007)	1
-44	Screw, Round Head, #6-32 X 2-1/4" Lg., Cad Pl.	2
-45	Washer, Flat, #6-32	2
-46	Nut, Hex, #6-32, S/S, Elastic Stop	2

*Recommended Spare Parts
S/S - Stainless Steel

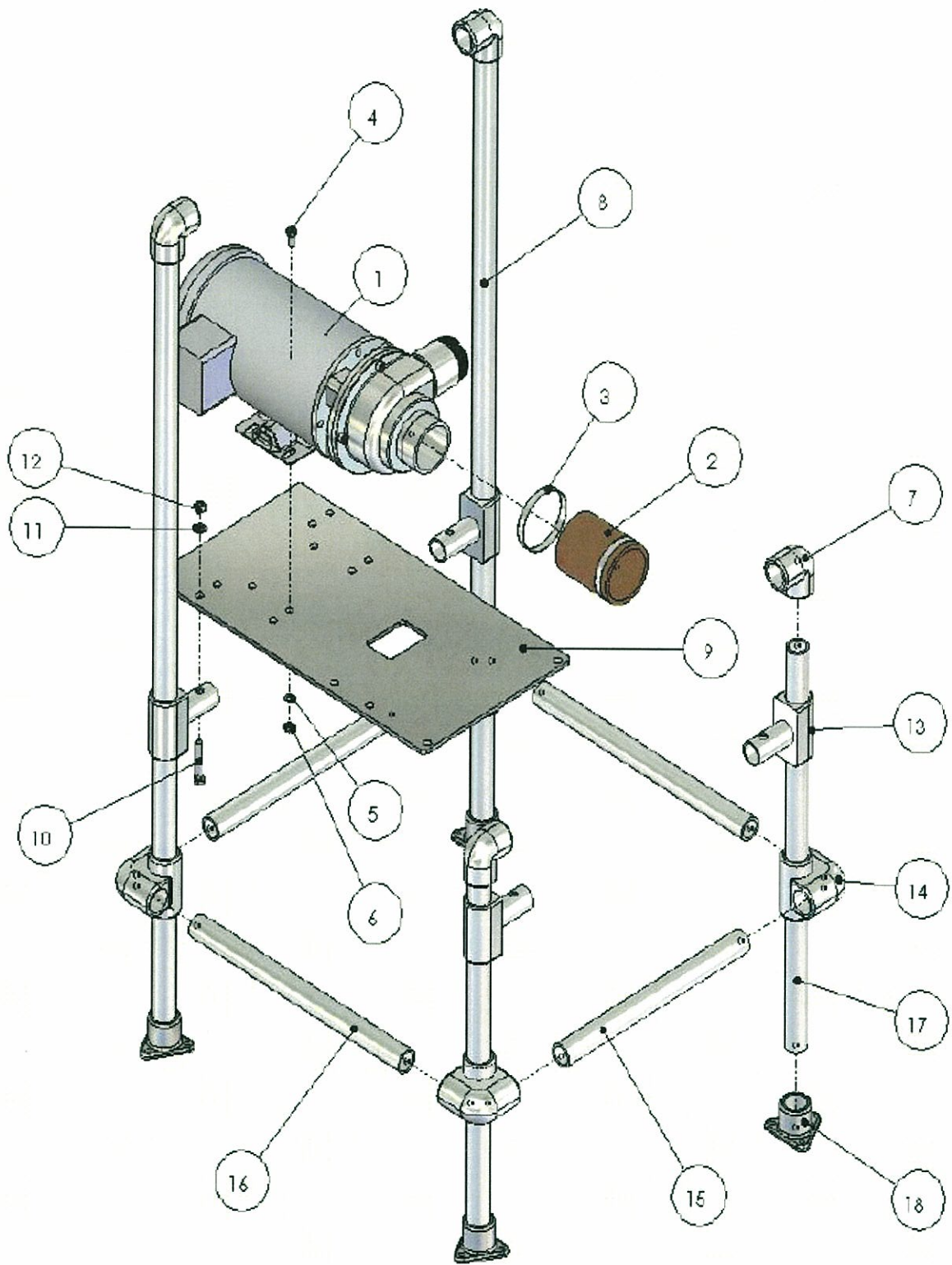

FIGURE 4. STAND ASSEMBLY, DIRECT DRIVE PUMP - EXPLODED VIEW

FIG. & INDEX NO.	DESCRIPTION	REQ.
4-	<i>STAND ASSEMBLY, DIRECT DRIVE PUMP</i>	
-1	Pump, 3HP (85615-2), 5HP (85616-2) (See Pump Section for detailed parts break-down) (ATTACHING PARTS)	1
-2	Hose, 2-7/8" ID X 4" Lg. (36230)	1
-3	Clamp, #QS200M-48S, S/S (21870)	2
-4	Screw, Hex Hd., 5/16-18 X 3/4" Lg., Cad Pl.	4
-5	Washer, Lock, Cad Pl., 5/16" ID, Split Type Cad Pl.	4
-6	Nut, Hex, Cad Pl., 5/16-18 ---*---	4
-7	Fitting, Speed Rail, #3, 1 NPS (30900)	4
-8	Pipe, 1 NPS, SCH 40, 50-3/8" Lg. Alum.	2
-9	Plate, Pump Mounting, (80400) (ATTACHING PARTS)	1
-10	Screw, Hex Hd, 3/8-16 X 2-1/4" Lg. Cad Pl.	4
-11	Washer, Lock, Cad Pl., 3/8" ID, Split Type	4
-12	Nut, Hex, Cad Pl., 3/8-16, ---*---	4
-13	Swivel Fitting, 1 NPS (30910)	4
-14	Fitting, Speed Rail, No. 5 Tec, 1 NPS (30920)	4
-15	Pipe, 1 NPS, SCH 40, 14-1/4" Lg. Alum	2
-16	Pipe, 1 NPS, SCH 40, 16-1/2" Lg. Alum.	2
-17	Pipe, 1 NPS, SCH 40, 24-9/16" Lg. Alum	2
-18	Floor Flange, 1 NPS (30940)	4

FIG. & INDEX NO.	DESCRIPTION	REQ.
---------------------	-------------	------

PIPING COMPONENTS FOR HE-6S-3 HYDRA-EXTRACTOR

HE-6S-3 FRESH HOT WATER ASSEMBLY

Gate Valve, 1/2" (64803)	1
Backflow Preventor, 1/2" (11310)	1
Shock Arrestor, 1/2" (11303)	1
Solenoid Valve, 1/2" (64710)	1

HE-6S-3 RETURN WATER ASSEMBLY

Check Valve, 2" (64870)	1
Motor Operated Valve, 1-1/2" (64735-4)	1
Gate Valve, 1-1/2" (64825)	1

NOTE: ABOVE ITEMS NOT PICTURED

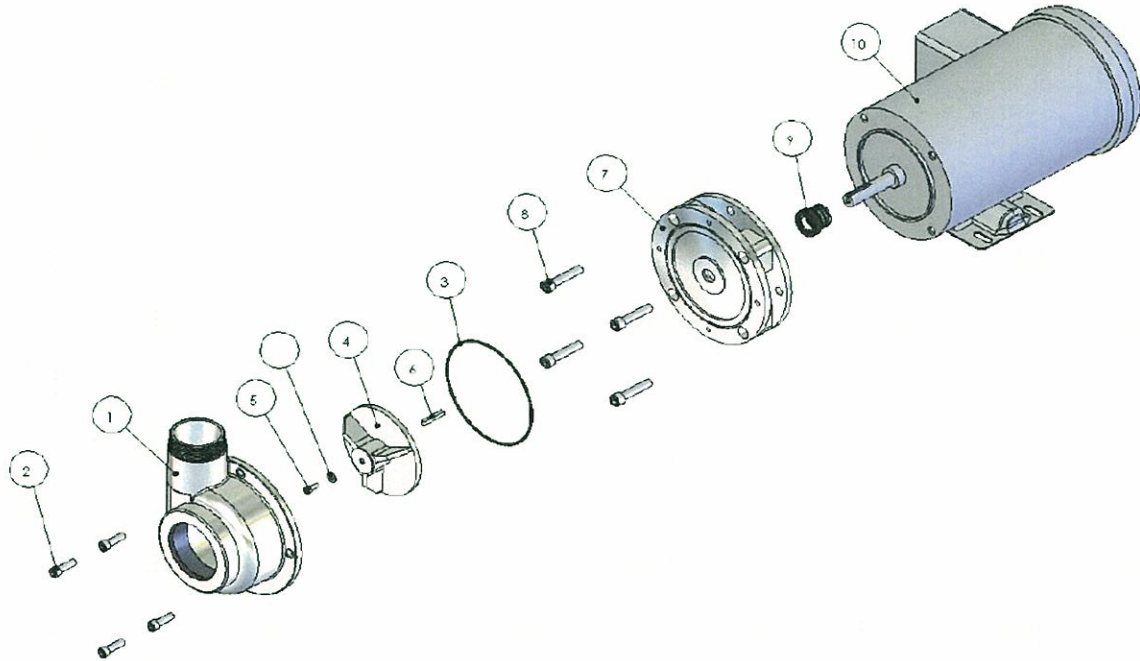

FIGURE 2. KW DIRECT DRIVE PUMP EXPLODED VIEW

FIG AND INDEX NO. REQ.	DESCRIPTION	
2-	<i>PUMP ASSEMBLY, K/W DIRECT DRIVE</i>	
-1	Housing, Pump (83200-2) (ATTACHING PARTS)	1
-2	Screw, Socket Head, 5/16-18 x 3/4" Lg. ---*---	4
-3	"O" Ring (45700)	1
-4	Impeller, 2HP (84153-2), 3HP (84152-2), 5HP (84151-2) (ATTACHING PARTS)	1*
-5	Screw, Socket Head, #10-32 x 5/8" Lg.	1
-6	Key, 3/16 x 3/16 x 1-1/8" Lg. ---*---	1
-7	Ring, Spacer, 2HP and 3HP (86300-2), 5HP (86301-2) (ATTACHING PARTS)	1
-8	Screw, Socket Head, 3/8-16 x 1-3/4" Lg. ---*---	4
-9a	Seal, Mechanical, 5/8" 2HP and 3HP (54300)	1*
-9b	Seal, Mechanical, 7/8" 5HP (54302)	1*
-10a	Motor, 2HP (41640)	1
-10b	Motor, 3HP (41652)	1
-10c	Motor, 5HP (41708)	1

* Recommended Spare Parts