



SPC-75S

WASTE REDUCTION SYSTEM



The **Somat SPC-75S** Waste Reduction System processes up to 1,250 lbs. of food service waste per hour providing an economic and efficient answer to cutting the high and ever increasing costs associated with waste handling. Somat Pulping Systems are engineered to reduce foodservice waste volume by an 8 to 1 reduction (up to 85%.) Compostable waste enters the pulping tank via the feed tray or scrapping trough where it mixes with water and is ground into a slurry. The slurry is fed to the Hydra-Extractor® for de-watering and the result is a semi-dry pulp discharged into a haul-away container or a Somat Dehydrator for additional reduction. The extracted water is recovered and returned to the pulping tank for re-use by the tray or trough.

VOLTAGE OPTIONS

- 208/60/3
- 230/60/3
- 460/60/3
- International options available, consult factory

STANDARD FEATURES

- Hinged lid pulper with limit switch
- Hydra-Extractor
- 3 HP recirculating pump
- Valve package
- Chemical additive pump
- Som-A-Trol control panel

TECHNICAL SPECIFICATIONS

Pulper:

- 30" diameter, 39.5" high max (legs fully extended)
- Polished stainless steel tank
- Hinged lid with limit switch
- 3/8" stainless slurry chamber
- 7½ HP TEFC direct drive motor
- Internal collection box
- "Hypoint" style cutting mechanism, featuring:
 - Stainless steel impeller
 - Two hardened corrosion resistant alloy rotating blades
 - Four carbide stationary blades

Hydra-Extractor

- Welded stainless steel construction
- Stainless steel adjustable legs
- 2 HP TEFC drive motor
- 20:1 gear reducer
- 3HP TEFC recirculating pump
- Chemical pump
- 6" stainless steel auger with nylon brush edge
- Reinforced stainless steel screens
- Automatic shutdown timer
- Automatic rinse system
- Discharge chute with safety switch

Valve Package:

- All valves required for operation including fresh water, return and drain lines.

Som-A-Trol Electrical Control Panel:

- UL approved stainless steel NEMA 4 panel with all components pre-wired to internal terminal strip. Push Button control station on panel door (remote control station optional). Panel to be wall mounted with field connection to pulper mounted junction box.

OPTIONS

- Water flushed feed tray
- Trough feed connection
- Feed tray cover
- Prison package
- Under dish table unit
- Vibration pads
- Remote push button station
- Grabber magnets

The Power to Transform WASTEFUL to SUSTAINABLE

SPC-75S

HIGH TANK WITH TRAY FEED

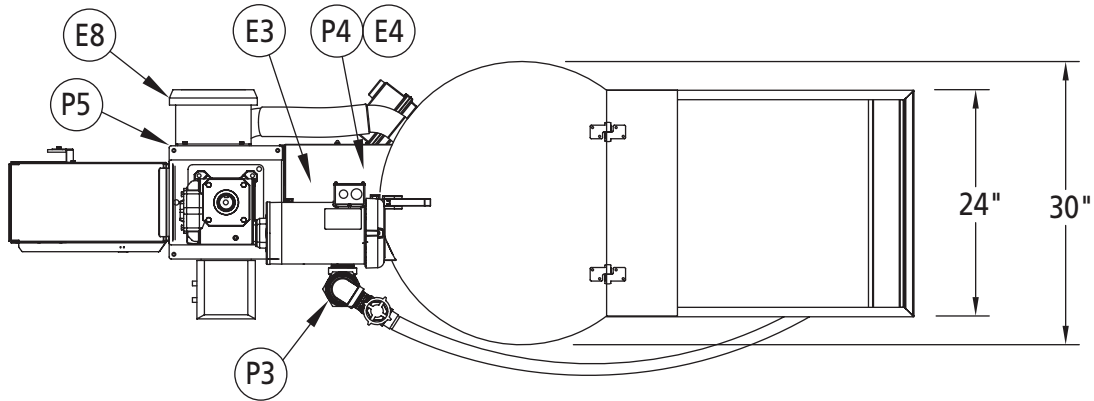

REMOTE UTILITY CONNECTION INFO			
E1	Pulper Drive Motor	P1	Drain Valve Outlet (MOV)
E2	Extractor Drive Motor	P2	Auto-Rinse Inlet
E3	Return Pump Motor	P3	Return Water Outlet
E4	Fresh Water Solenoid	P4	Fresh Water Inlet
E5	Pulper Limit Switch	P5	Overflow Outlet
E6	Chute Limit Switch	P6	Tray Flush (see next page)
E7	Chemical Additive Pump		
E8	Junction Enclosure		
E9	Autorinse Solenoid		

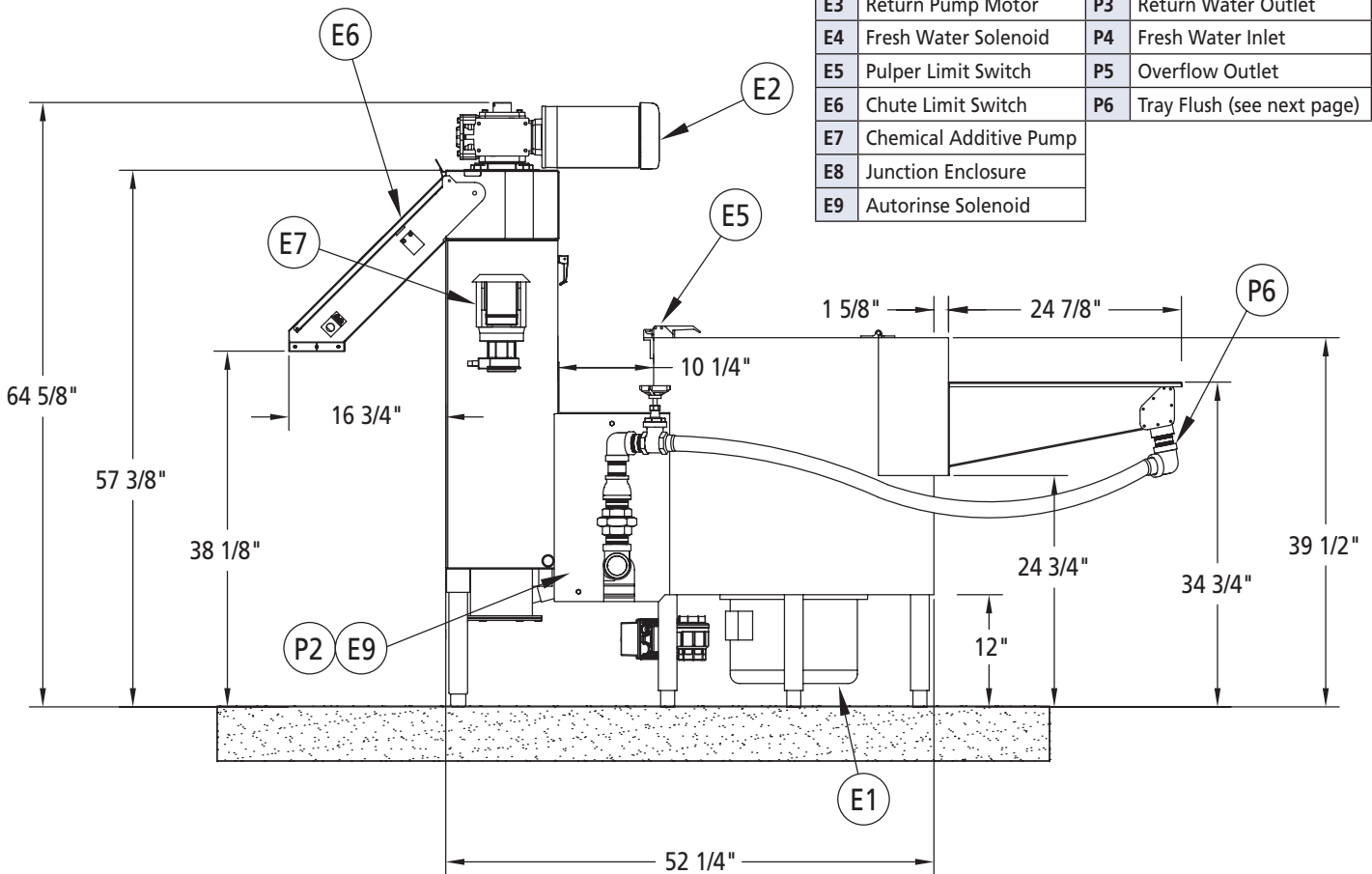

SPECIFICATIONS							
Total Height	Tank Height	Length	Width	Equipment Weight	Operating Weight	Crated Weight	Crated Volume
65" (1,651 mm)	43" (1,093 mm)	95.875" (2,435 mm)	30" (762 mm)	900 lbs. (408 kg)	1,155 lbs. (524 kg)	1,175 lbs. (533 kg)	167 cu. ft.

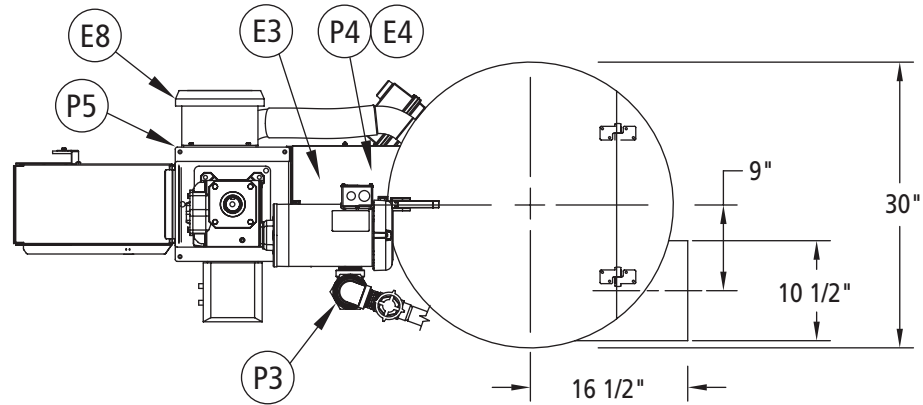

REMOTE UTILITY CONNECTION INFO			
E1	Pulper Drive Motor	P1	Drain Valve Outlet (MOV)
E2	Extractor Drive Motor	P2	Auto-Rinse Inlet
E3	Return Pump Motor	P3	Return Water Outlet
E4	Fresh Water Solenoid	P4	Fresh Water Inlet
E5	Pulper Limit Switch	P5	Overflow Outlet
E6	Chute Limit Switch	P6	Tray Flush (see page 4)
E7	Chemical Additive Pump		
E8	Junction Enclosure		
E9	Autorinse Solenoid		

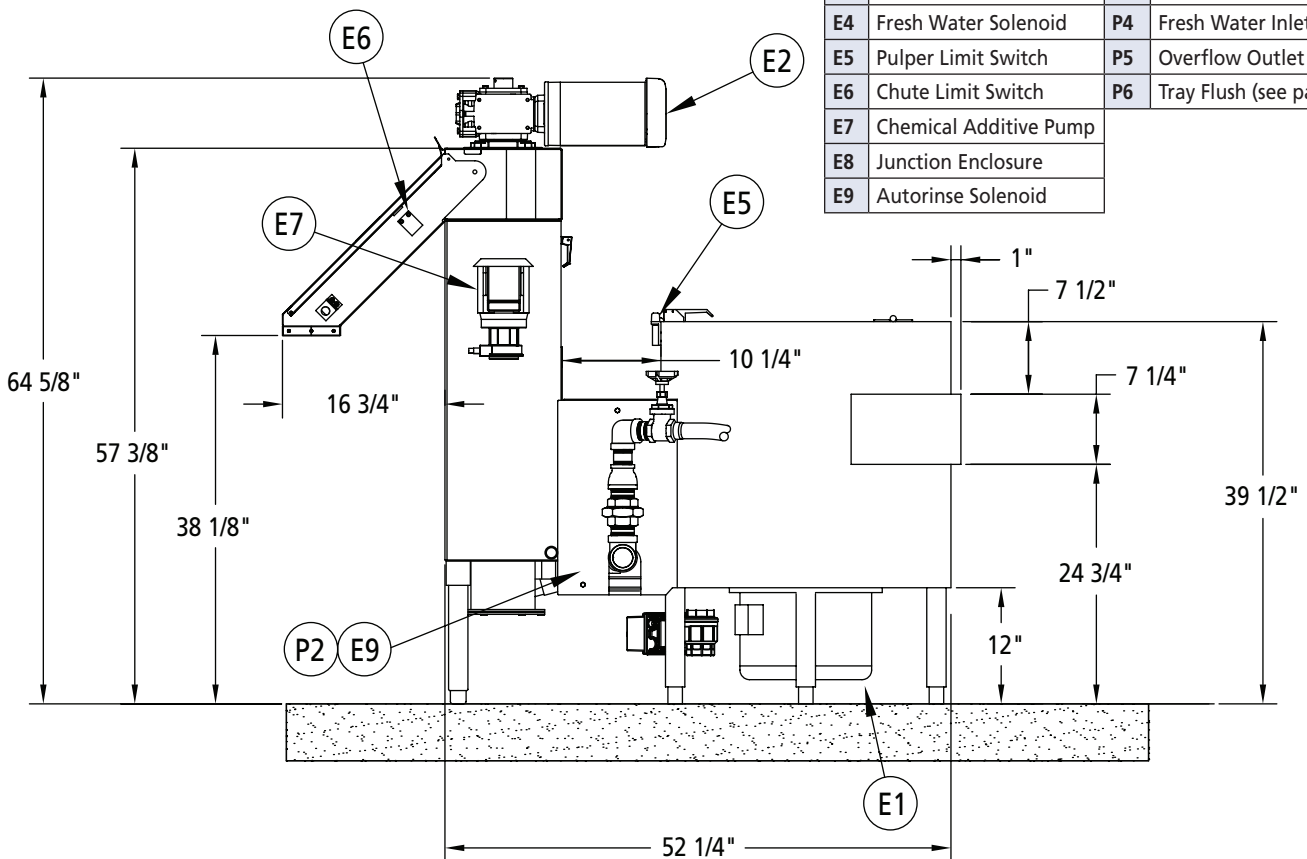

SPECIFICATIONS							
Total Height	Tank Height	Length	Width	Equipment Weight	Operating Weight	Crated Weight	Crated Volume
65" (1,651 mm)	43" (1,093 mm)	70" (1,778 mm)	30" (762 mm)	900 lbs. (408 kg)	1,155 lbs. (524 kg)	1,175 lbs. (533 kg)	167 cu. ft.

SPC-75S

WASTE REDUCTION SYSTEM

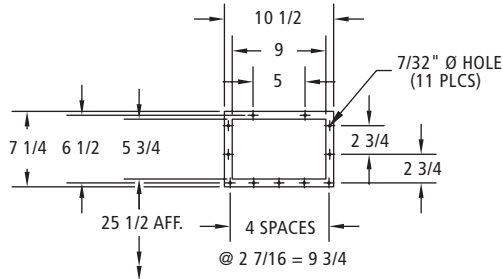

9" TROUGH FLANGE DETAIL

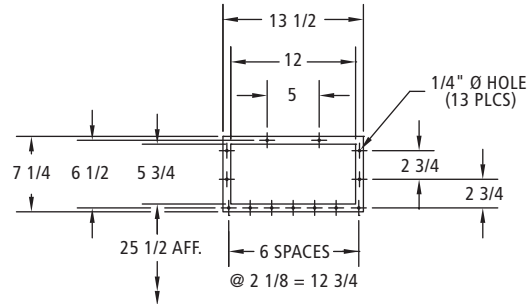

12" TROUGH FLANGE DETAIL

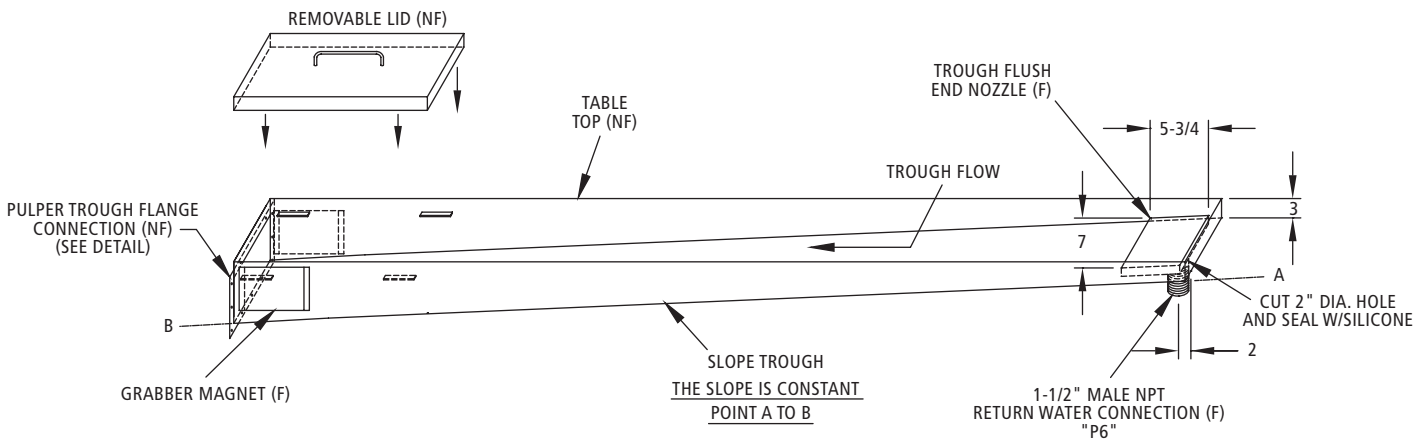

PULPER TROUGH DETAIL

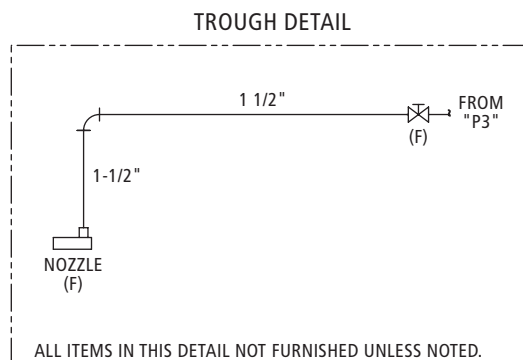

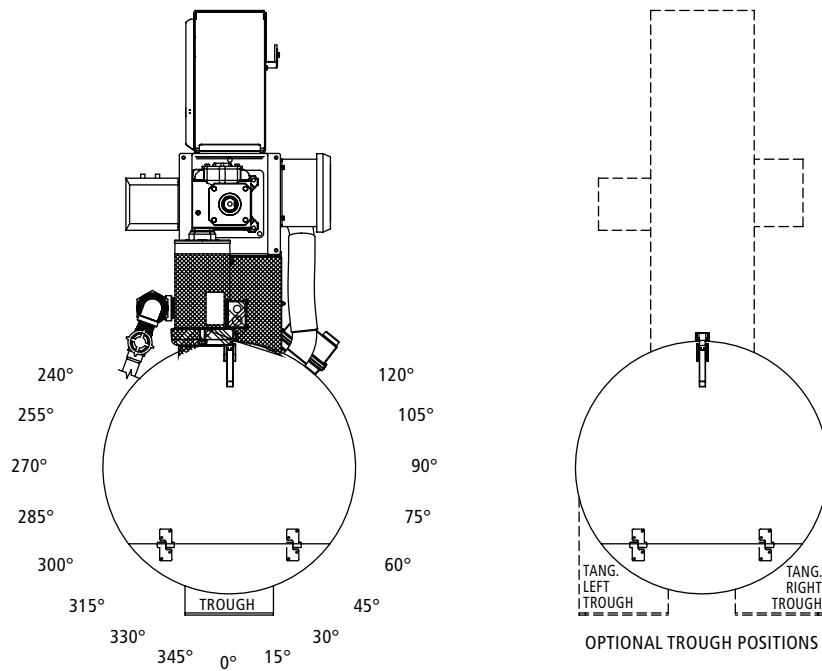

TROUGH LOCATION SHOWN AT 0 DEGREES, CENTER POSITION

TROUGH CAN BE ROTATED ON THE CENTER POINT OF THE TANK BY 15 DEGREE INCREMENTS, ACTUAL ENTRY POINTS TO THE TANK WILL DEPEND ON TROUGH ORIENTATION, LEFT, RIGHT OR CENTER POSITION, TROUGH CAN NOT COME IN CONTACT WITH EXTRACTOR AREA (SHADED PORTION).

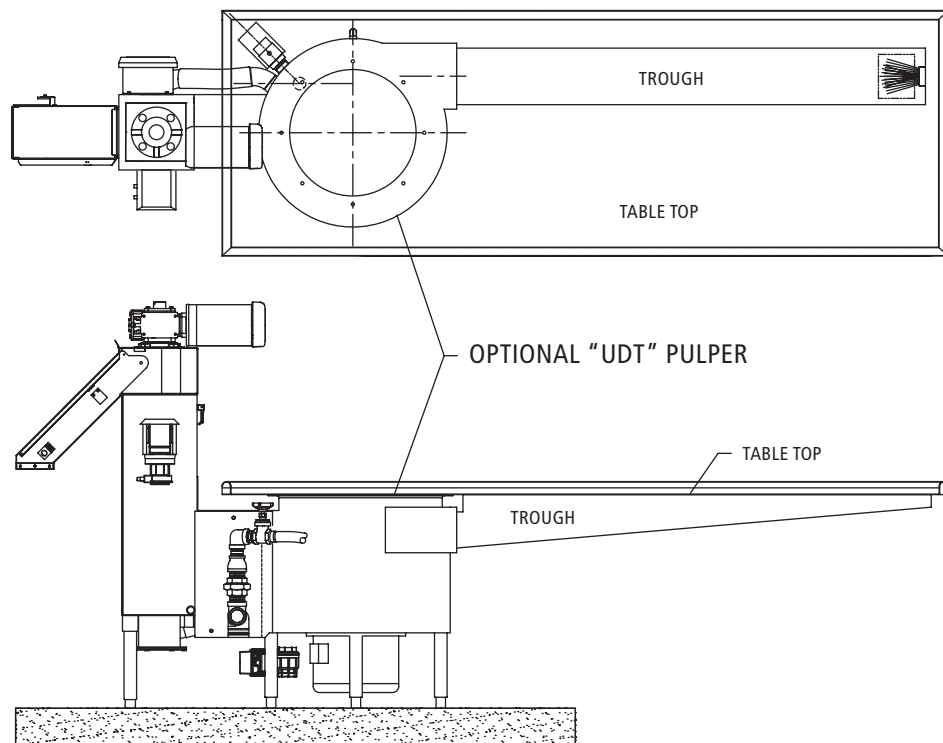

SPC-75S

WASTE REDUCTION SYSTEM



CUSTOMER POWER SUPPLY
(BY ELECTRICAL CONTRACTOR)
208V-3Ø-60Hz-45AMPS

460V-3Ø-60Hz-25AMPS

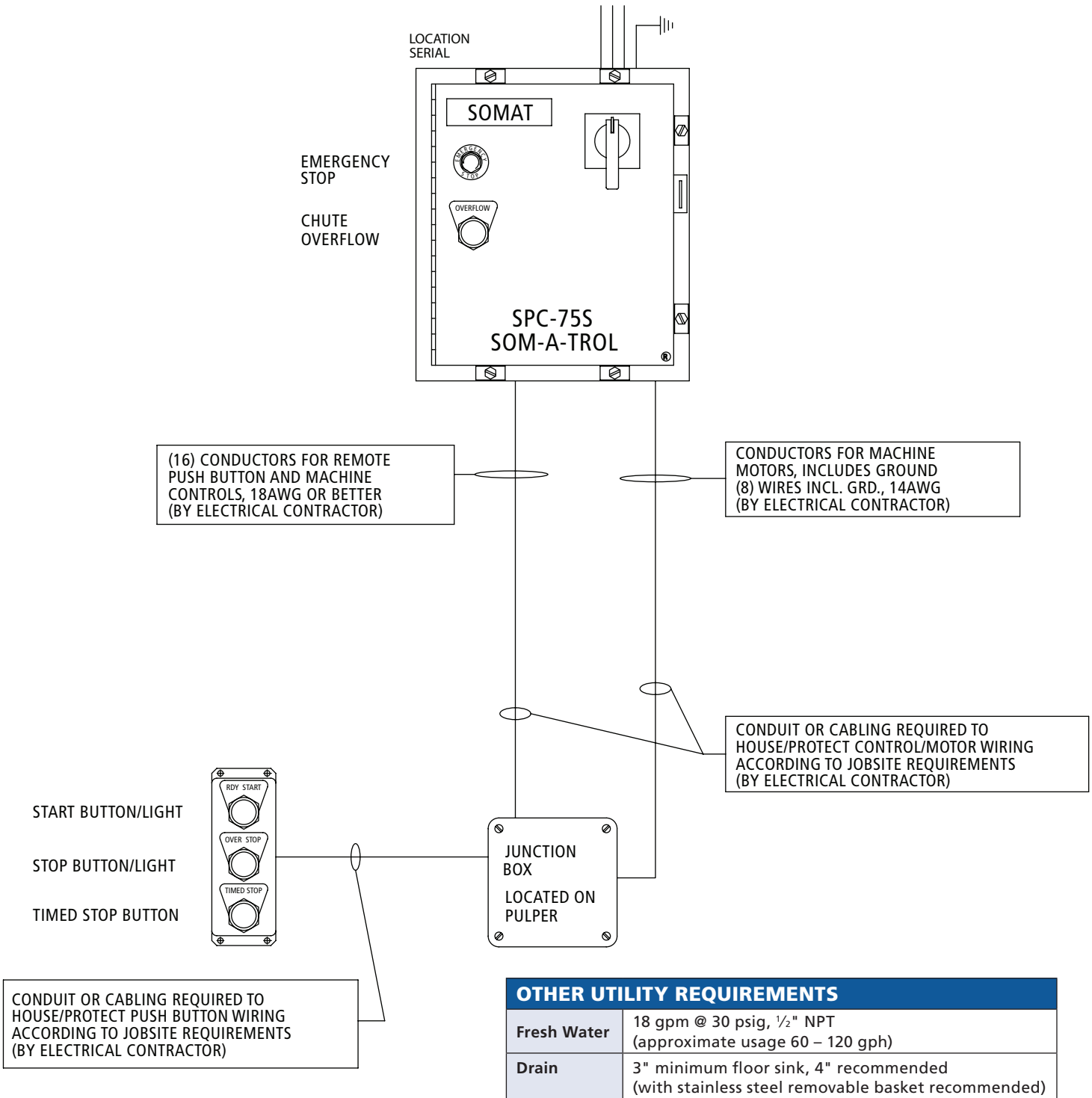

OTHER UTILITY REQUIREMENTS

Fresh Water	18 gpm @ 30 psig, 1/2" NPT (approximate usage 60 – 120 gph)
Drain	3" minimum floor sink, 4" recommended (with stainless steel removable basket recommended)