

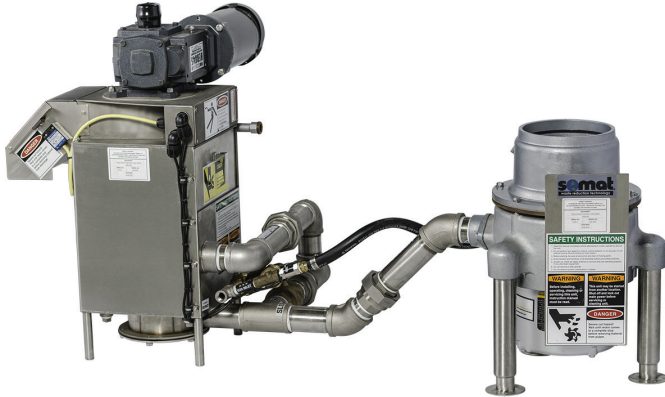

MP4/B-5

FOOD WASTE REDUCTION SYSTEM



The **SOMAT MP4/B5** Food Waste Reduction System features a Master B-5 Food Grinder, Somat MP4 Mini Press and a SOM-A-TROL control panel with pushbutton station. The grinder can be mounted in a trough, table or sink. Food waste enters the grinder and mixes with water where it is ground into a slurry. The slurry is automatically transported through a pipeline to the MP4 Mini Press, where water is removed and the resultant semi-dry pulp is discharged into a haul-away container. The extracted water can be recovered and returned to the grinder with an optional return pump. The **MP4/B5** Food Waste Reduction System can be engineered to fit in most scrapping areas, existing or new. It can even replace an current disposer. The MP4 Mini Press can be installed anywhere within 8 feet of the grinder, facing any direction, it can even fit under a table to maximize space.

TECHNICAL SPECIFICATIONS

- **Food Grinder:** 5 HP food waste grinder, 10 $\frac{5}{8}$ " diameter turntable with an adjustable 45 degree angle impact breakers constructed of hardened ductile steel alloy. Matching sizing ring with 24 grinding teeth. 8 $\frac{1}{4}$ " throat opening allows for fast feeding. Flexible neoprene installation collar eliminates vibration. Bolt on motor and grind chamber allows replacement of all wearing parts without disturbing plumbing and electrical connections. Adjustable legs to level disposer and meet drain stub. Shaft extension with $\frac{3}{4}$ " wrench flats to externally de-jam foreign matter. Heavy cast alloy construction provides extra long life.
- **Mini Press:** $\frac{3}{4}$ HP drive motor. 6" stainless steel vertical auger with brush tipped flighting. Screen with .093" diameter holes. Discharge chute lid features a magnetic limit switch for safety. Can be configured to fit any floor plan.
- **Som-A-Trol® (Electrical Control Panel):** UL approved. Includes all necessary power, control and water level components prewired to a terminal strip. Push button station in a NEMA 4 stainless steel enclosure.
- **Valve Package:** Pre-piped to include all valves required for proper operation.

ELECTRICAL

- 208/230/460 volt, 3 Phase, 60 Hertz

CAPACITY

- 700 pounds per hour of food waste only.

OPTIONS

- Sink mount
- Bowl mount
- Trough mount with return pump

BENEFITS

- As much as 8 to 1 (85%) volume reduction
- Uses fresh water for sanitary areas
- Small footprint
- Keeps solids from municipal waste system
- Simple operation and maintenance

Equipment only is supplied by Somat Company; installation, piping and wiring not included.

The Power to Transform WASTEFUL to SUSTAINABLE

MP4/B-5

FOOD WASTE REDUCTION SYSTEM

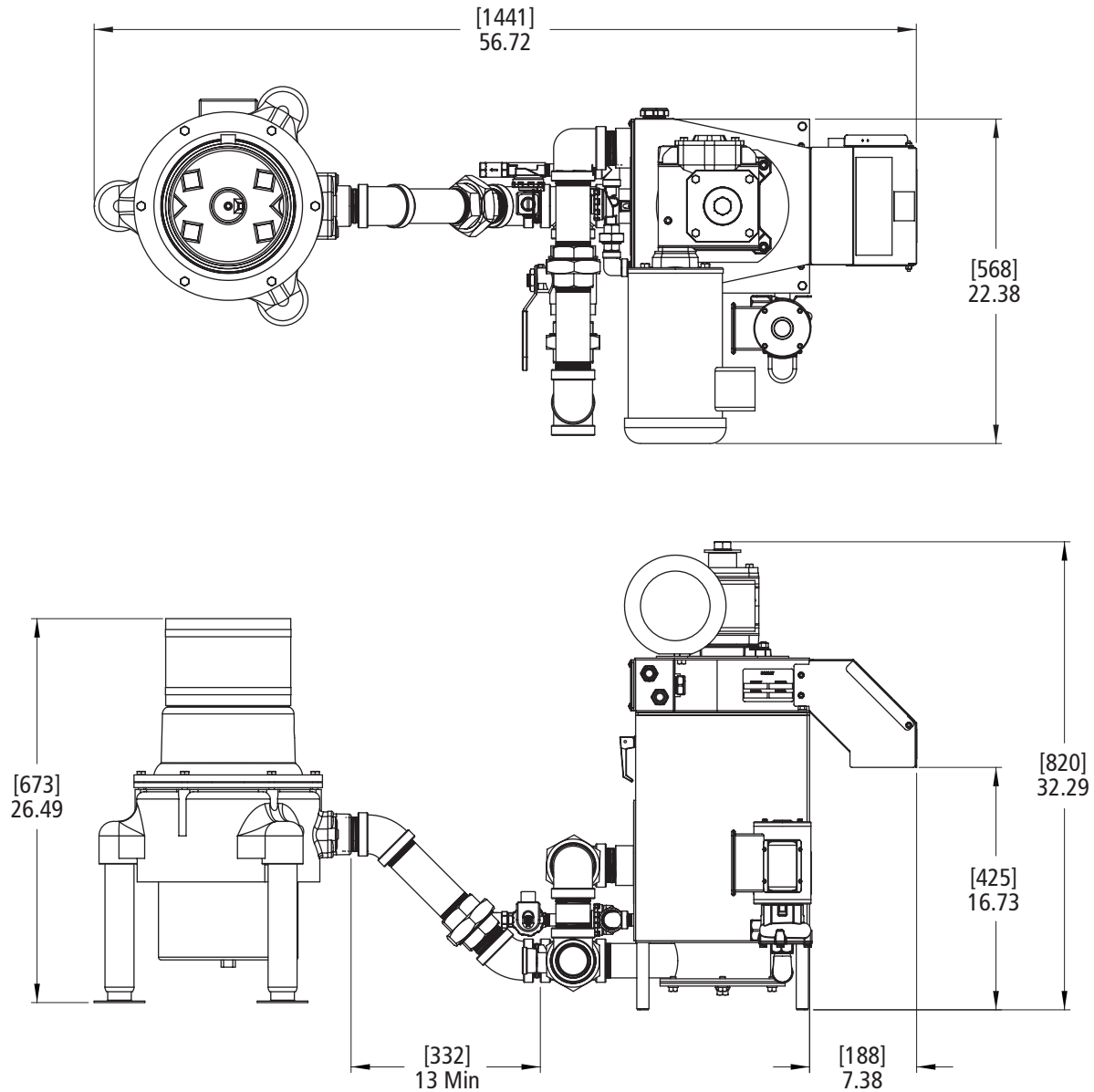

UTILITY REQUIREMENTS

Power (Electric) Connection	208V-25A; 460V-15A 3Ø 60Hz
Fresh Water Connection	½" cold water @ 30 psi, 2 gpm
Drain Connection	2" drain to 3" minimum floor sink

SPECIFICATIONS

Treatable Items	Foodservice waste only
Safety Feature	Discharge chute limit switch
Capacity	700 lb.s/hr.
Warranty	1 year manufacturer's standard warranty

In line with its policy to continually improve its products, Somat reserves the right to change materials and specifications without notice.