



HE6-GT

SECONDARY HYDRA-EXTRACTOR



The **Somat Model HE6-GT Secondary Hydra Extractor** is designed to operate in series with the Somat HE-6 or HE-9 Hydra-Extractor. Standard features include a 2 HP drive motor, automatic rinse system, and discharge chute with limit switch. During normal operation, a pulping system will discharge wastewater containing suspended solids which will impact the wastewater collection system, particularly in-ground grease traps. These solids will settle to the bottom of grease traps, decreasing effectiveness and increasing maintenance costs. The HE6-GT receives the wastewater flow from the primary extractor and removes most of the remaining solids. Reducing the number of solids in the waste water extends the volume of the trap. Reducing the solids allows the service cycle of the trap to be limited by grease collection and not solids accumulation.

CAPACITY

400 gallons per hour of pulping waste water.

TECHNICAL SPECIFICATIONS

Hydra-Extractor:

- 2 HP TEFC drive motor
- 50:1 gear reducer
- Rigid stainless-steel weldment and head assembly
- Aluminum stand
- 6" stainless steel auger with nylon brush edge
- Reinforced stainless steel screens with .023" holes
- Automatic shutdown timer
- Automatic rinse system
- 17" Discharge chute with safety switch

Valve Package:

All valves required for proper operation (automatic rinse system).

Som-A-Trol® (Electrical Control Panel):

UL approved, includes all necessary electrical components prewired to a terminal strip in a NEMA 4 stainless steel enclosure. Control of the HE6-GT is incorporated within the control scheme of other components in the Somat Pulping System.

OPTIONS

- Extended discharge chute
- Hinged chute
- Extended stand
- Pulp level detector

VOLTAGE OPTIONS

- 208/60/3
- 230/60/3
- 460/60/3
- International options available, consult factory

FINISH

All exterior surfaces are stainless steel

The Power to Transform WASTEFUL to SUSTAINABLE

HE6-GT

SECONDARY HYDRA-EXTRACTOR

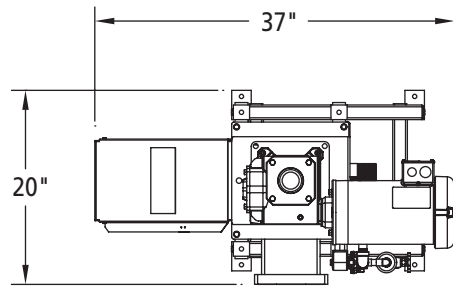

PLAN VIEW OF HE6-GT EXTRACTOR

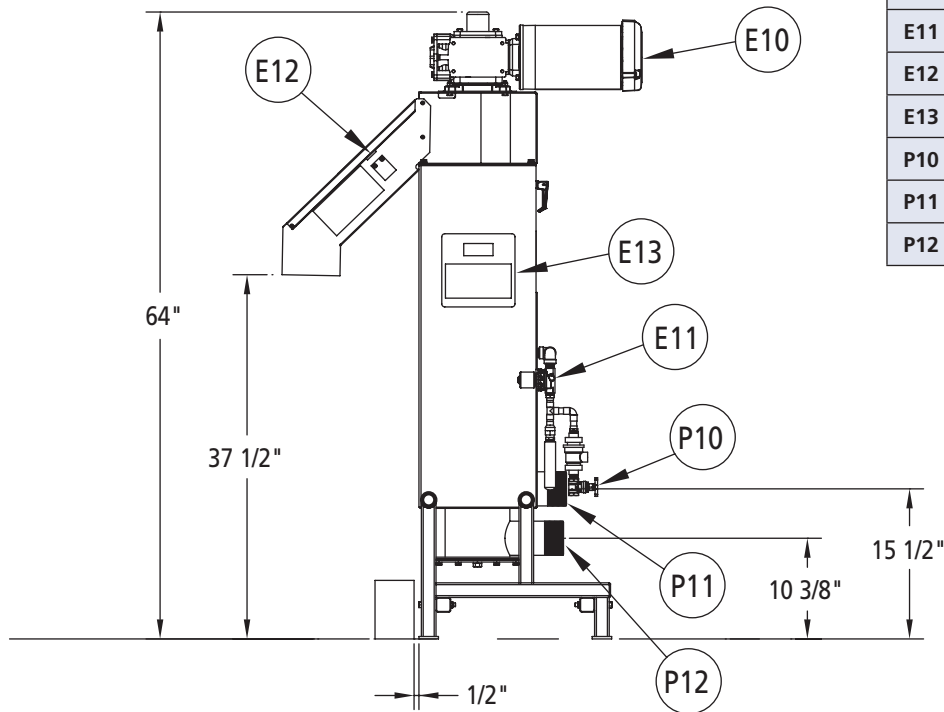

UTILITY CONNECTIONS	
E10	Press Drive Motor
E11	Fresh Hot Water Solenoid
E12	Chute Limit Switch
E13	Junction Box
P10	Press Rinse (Hot Fresh Water)
P11	Wastewater Outlet
P12	Wastewater Inlet

ELEVATION VIEW OF HE6-GT EXTRACTOR

DIMENSIONS			
Height	64" (1626mm)	Equipment Weight	400 lbs. (181kg)
Length	37" (940mm) (including chute)	Operating Weight	450 lbs. (204kg)
Width	20" (508mm)	Crated Weight	500 lbs. (227kg)
		Crated Volume	46 cu. ft.

OTHER UTILITY REQUIREMENTS	
Fresh Hot Water	4 gpm @ 45 psig, 1/2" NPT for clean out cycle only (approximately 40 gallons per cycle)
Drain	4" minimum floor sink, with stainless steel removable basket recommended

In line with its policy to continually improve its products, Somat reserves the right to change materials and specifications without notice.