



HE-9RT

REMOTE HYDRA-EXTRACTOR®



The **Somat HE-9RT Twin Hydra-Extractor®** is one part of a Remote Pulping System. Standard features include two 5 HP drive motors and return pump. The main benefits of a Somat Remote Pulping System are **Reduction** and **Transportation**. A remote system connects food prep and scrapping areas together through a series of piping and transports food service waste to a remote extractor. The extractor removes the solids (pulp) and recirculates the water back to the grinding tanks. The pulping process provides an 8 to 1 volume reduction (up to 85%.) The pulp is fed into a Somat Dehydrator for additional reduction or directly into a dumpster. A remote pulping system eliminates the need for trash cans, liners and laborers to “take out the trash”.

CAPACITY

5,000 pounds per hour of foodservice waste mix, consisting of food scraps, plastics, milk cartons, paper, aluminum foil and cardboard.

TECHNICAL SPECIFICATIONS

Hydra-Extractor:

- Twin 5 HP TEFC drive motors
- 25:1 gear reducers
- 7.5 HP TEFC return pump
- Stainless 2" angle iron frame
- Chemical additive pump
- Twin 9" stainless steel augers with nylon brush edges
- Reinforced stainless steel screens
- Automatic shutdown timer
- Automatic rinse systems
- 28" Discharge chute with safety switch

Valve Package:

- All valves required for proper operation (automatic rinse system).

Som-A-Trol Electrical Control Panel:

- UL approved stainless steel NEMA 4 panel with all components pre-wired to internal terminal strip. Push Button control station on panel door (remote control station optional). Panel to be wall mounted with field connection to pulper mounted junction box.

OPTIONS

- Extended discharge chute
- Hinged chute
- 10 HP TEFC return pump
- Extended stand
- Special electrical characteristics
- Pulp level detector

Special Requirements:

- Pulp Screw Conveyor and controls. Required to convey pulp from discharge chute to haulaway container when location of container does not permit gravity discharge.

Voltage Options:

- 208/60/3
- 230/60/3
- 460/60/3
- International options available, consult factory

FINISH

Exterior surfaces and frame are powder coated stainless steel.

The Power to Transform WASTEFUL to SUSTAINABLE

HE-9RT

REMOTE HYDRA-EXTRACTOR®

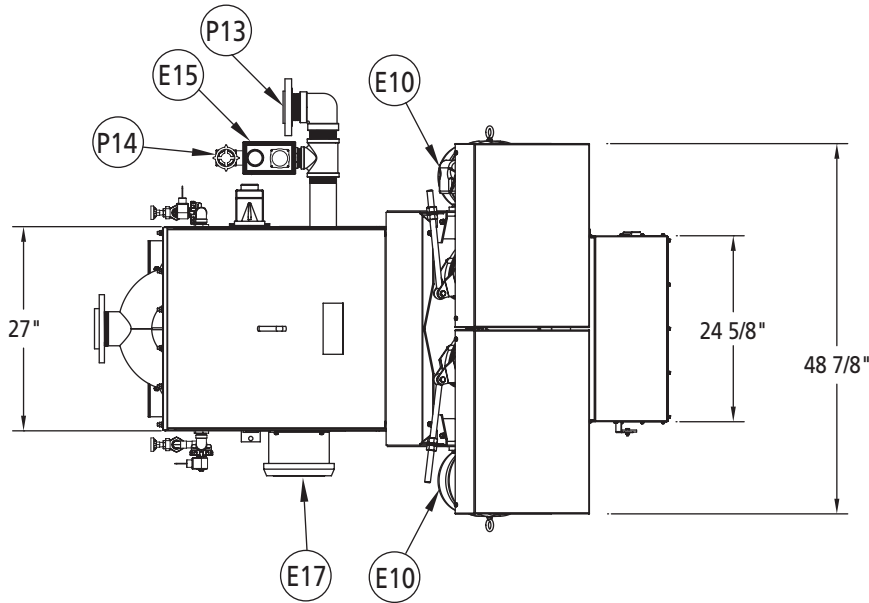

PLAN VIEW OF HE-9RT EXTRACTOR

UTILITY CONNECTIONS	
E10	Extractor Drive Motor (5 HP)
E11	Return Pump Motor (7.5 HP)
E12	Chemical Additive Pump
E13	Fresh Hot Water Solenoid
E14	Chute Limit Switch
E15	Autorinse MOV
E16	Pulp Level Detector
E17	Junction Enclosure
P10	Fresh Hot Water Inlet
P11	Overflow Outlet
P12	Slurry Inlet
P13	Return Water Outlet
P14	Autorinse to Drain

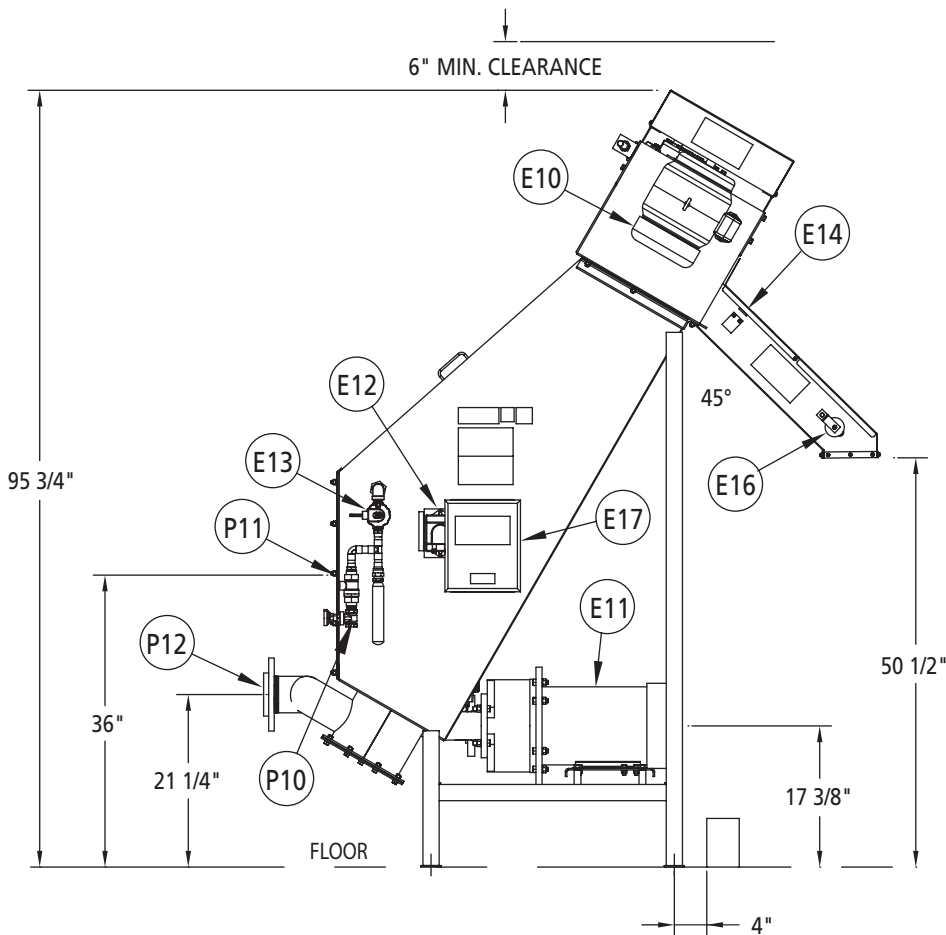

ELEVATION VIEW OF HE-9RT EXTRACTOR

DIMENSIONS	
Height	96" (2439mm)
Length	76" (1931mm) (Not including chute)
Width	60" (1524mm)
Equipment Weight	1,660 lbs. (753kg)
Operating Weight	1,995 lbs. (905kg)
Crated Weight	1,760 lbs. (799kg)
Crated Volume	128 cu. ft.

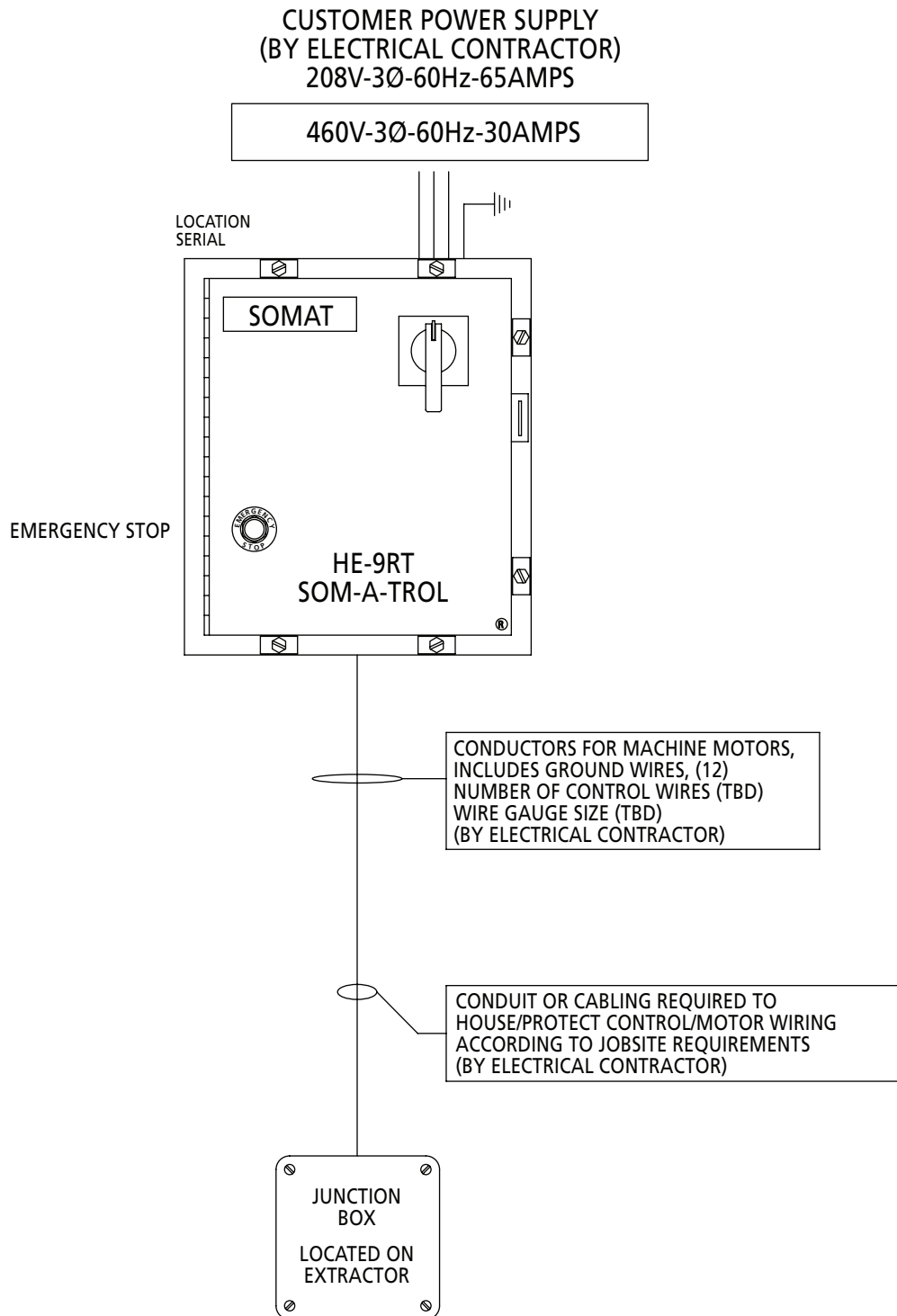

OTHER UTILITY REQUIREMENTS

Fresh Hot Water	18 gpm @ 45 psig, 3/4" NPT (For clean out cycle only, approximately 160 gallons per cycle)
Drain	6" minimum floor sink, with stainless steel removable basket recommended)