



D-5

FOOD WASTE GRINDER



The **Somat D-5 Food Waste Grinder** is one part of a Remote Pulping System. Somat food grinders are engineered to process food waste and are typically placed in pot and pan washing and food prep areas. Standard features include a 5 HP drive motor and return pump. The main benefits of a Somat Remote Pulping System are **Reduction** and **Transportation**. A remote system connects food prep and scrapping areas together through a series of piping and transports food service waste to a remote extractor. The extractor removes the solids (pulp) and recirculates the water back to the grinding tanks. The pulping process provides an 8 to 1 volume reduction (up to 85%.) The pulp is fed into a Somat Dehydrator for additional reduction or directly into a dumpster. A remote pulping system reduces the need for trash cans, liners and laborers to “take out the trash”.

CAPACITY

400 pounds per hour of food waste only.

TECHNICAL SPECIFICATIONS

Food Grinder:

- 5 HP continuous duty motor with shaft extension, $\frac{3}{4}$ " wrench flats to externally de-jam
- Adjustable $10\frac{5}{8}$ " diameter rotor/turntable beveled at a 45° angle with 6 integral impact breakers constructed of hardened ductile steel alloy for long life use. Matching 45° sizing ring with 24 grinding teeth.
- $8\frac{1}{4}$ " throat opening with dual directional operation, doubling the life cycle of the cutting mechanism.
- Grinder connects to Cone or Sink Assembly by means of a neoprene isolation sleeve and (2) stainless steel clamps.
- Stainless steel legs and feet, adjustable from 0" to 2".
- Foreign matter without special tools.
- Thermal overload protection with manual reset button

Valve Package:

Pre-piped valve package assemblies to include all valves required for proper operation.

Som-A-Trol® (Electrical Control Panel):

UL approved, Includes all necessary power, control and water level components prewired to a terminal strip. Push button station in a NEMA 4 stainless steel enclosure

OPTIONS

- Sink adapter w/ silver saver
- 3 or 5 HP return pump

VOLTAGE OPTIONS

- 208/60/3
- 230/60/3
- 460/60/3
- International options available, consult factory

FINISH

Basic body components are cast gray iron, machined, primed and powder coated.

The Power to Transform WASTEFUL to SUSTAINABLE

D-5

FOOD WASTE GRINDER

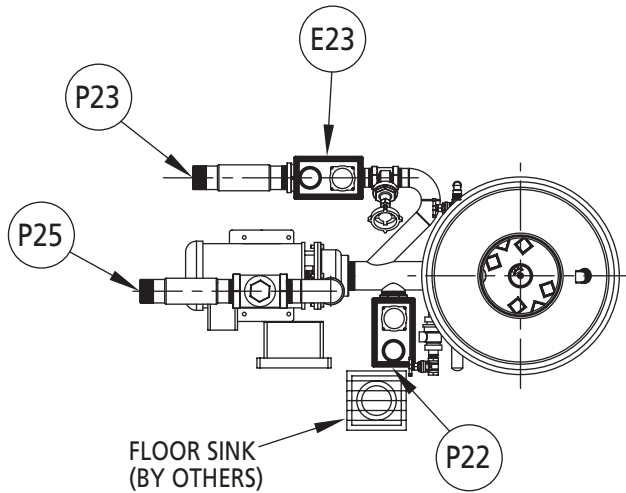

PLAN VIEW D-5 WASTE GRINDER
(DISPOSER BOWL)

NOTE: CUT 19"Ø HOLE IN TABLE TOP FOR BOWL, BOWL PROVIDED BY SOMAT, INSTALLED BY OTHERS.

UTILITY CONNECTIONS	
E21	Disposer Drive Motor
E22	Slurry Pump Motor
E23	Return line MOV
E24	Fresh Water Solenoid Valve
E25	Junction Enclosure
E26	Control Box (not shown)
P22	Drain MOV
P23	Return Water Inlet
P24	Fresh Water Inlet
P25	Slurry Outlet

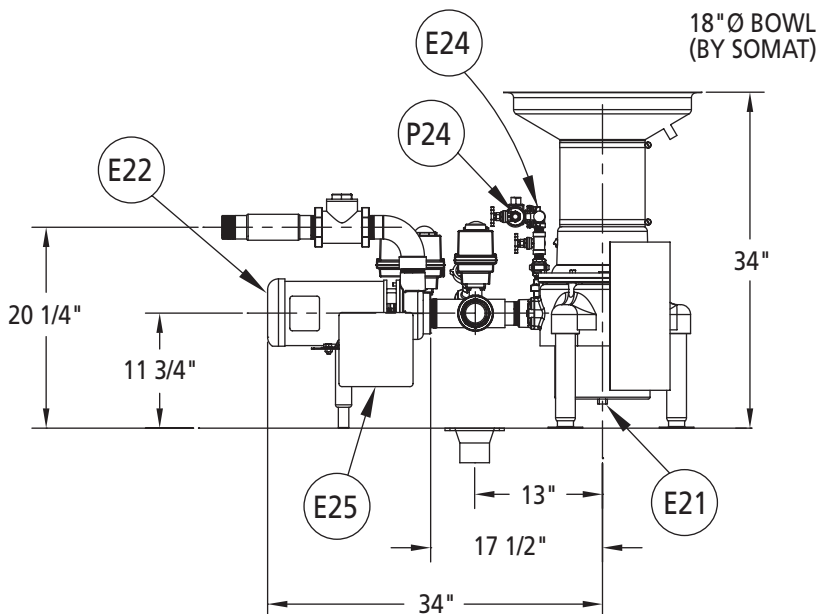

ELEVATION VIEW D-5 WASTE GRINDER
(DISPOSER BOWL)

DIMENSIONS	
Height	34" (865mm)
Length	46" (1150mm)
Width	22" (560mm)
Equipment Weight	375 lbs. (170kg)
Crated Weight	525 lbs. (238kg)
Crated Volume	85 cu. ft.

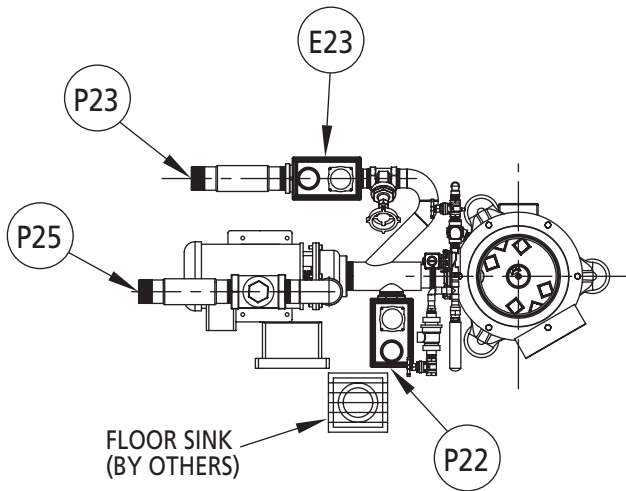

**PLAN VIEW D-5 WASTE GRINDER
(SINK ASSEMBLY)**

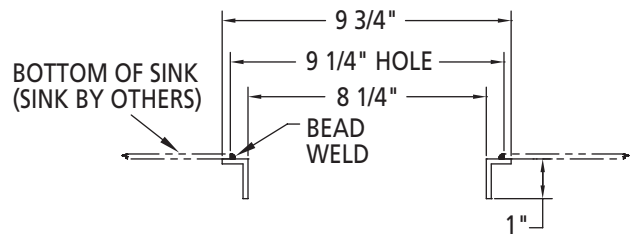

1. TABLE CUT 9 1/4" Ø HOLE IN BOTTOM OF SINK.
2. TACK WELD ADAPTOR TO UNDERSIDE OF SINK.
3. BEAD WELD ALL AROUND WHERE ADAPTER JOINS SINK.
4. MOUNT GRINDER TO SINK ADAPTER WITH PROVIDED HARDWARE.

**WASTE GRINDER SINK ADAPTER
MOUNTING DETAIL**

NOTE: ADAPTER RING BY SOMAT,
INSTALLED BY OTHERS.

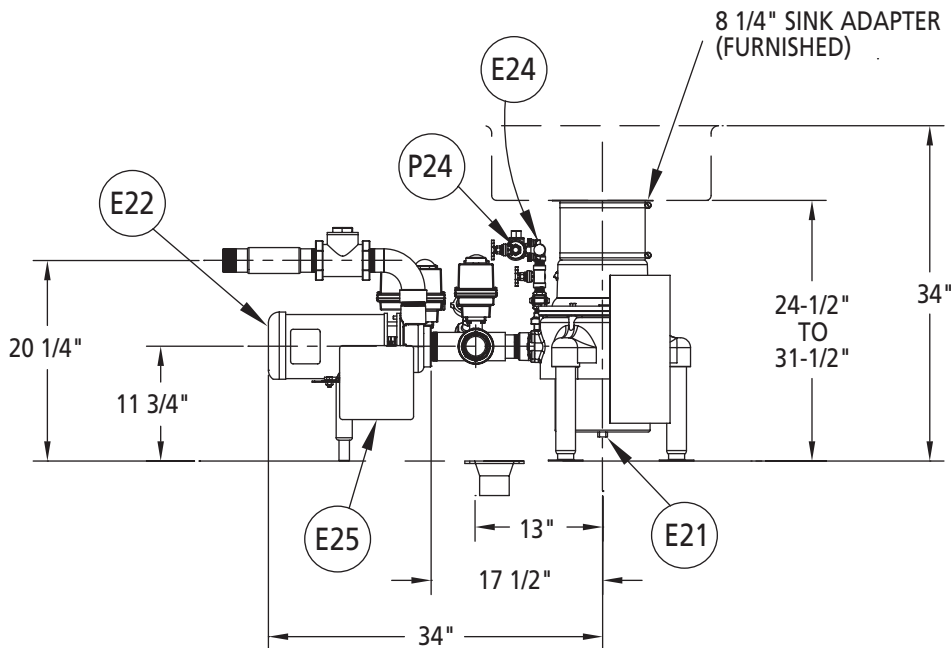

**ELEVATION VIEW D-5 WASTE GRINDER
(SINK ASSEMBLY)**

D-5 FOOD WASTE GRINDER

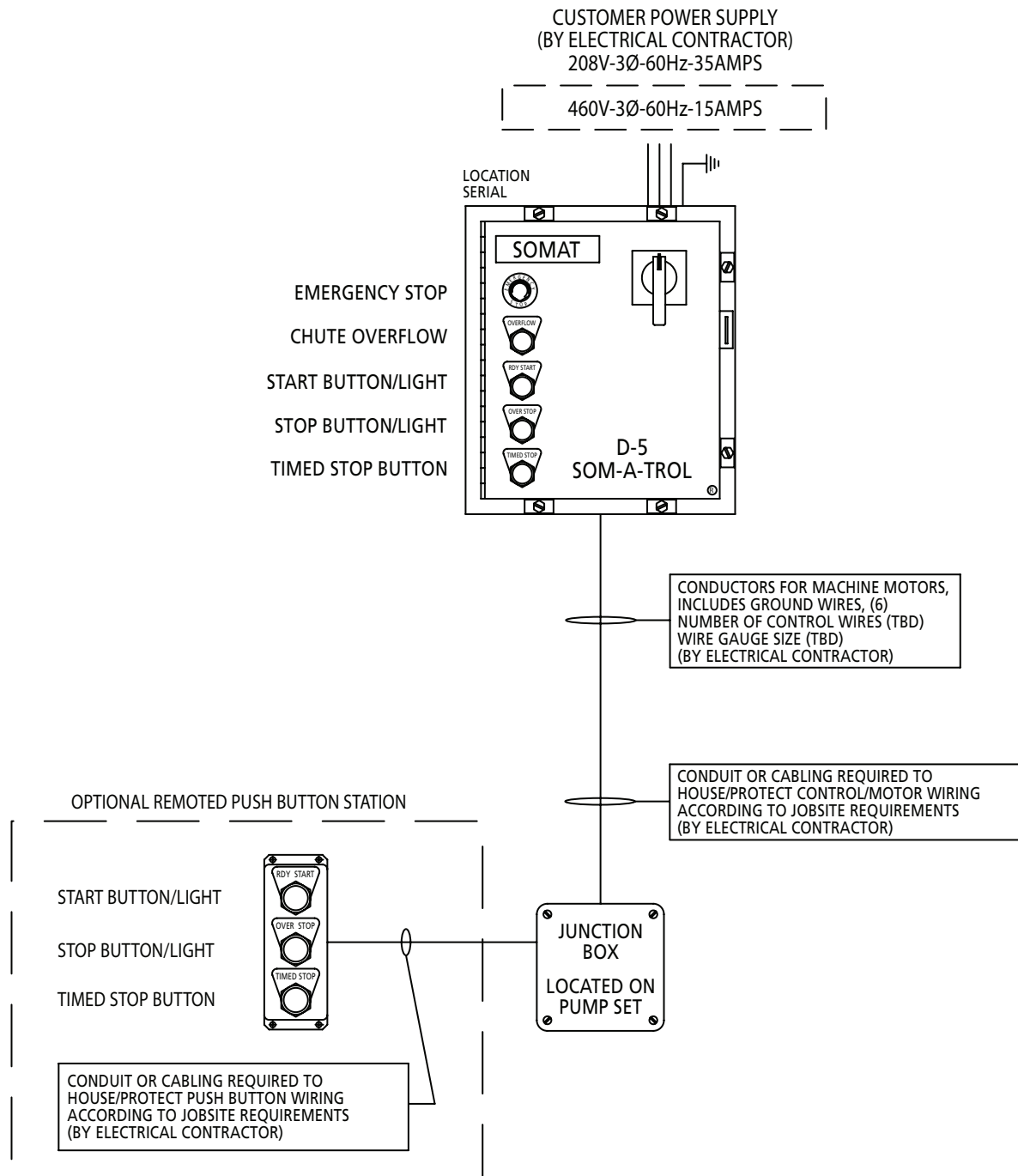

OTHER UTILITY REQUIREMENTS	
Fresh Water	4 gpm @ 30 psig, 1/2" NPT (approximate usage 240 gph)
Drain	3" minimum floor sink with stainless steel removable basket recommended
Power	208V-35Amps; 230V-30Amps; 460V-15 Amps, 3 phase, 60 Hz (w/5HP pump)

In line with its policy to continually improve its products, Somat reserves the right to change materials and specifications without notice.