

B SERIES REPLACEMENT PARTS DIAGRAM

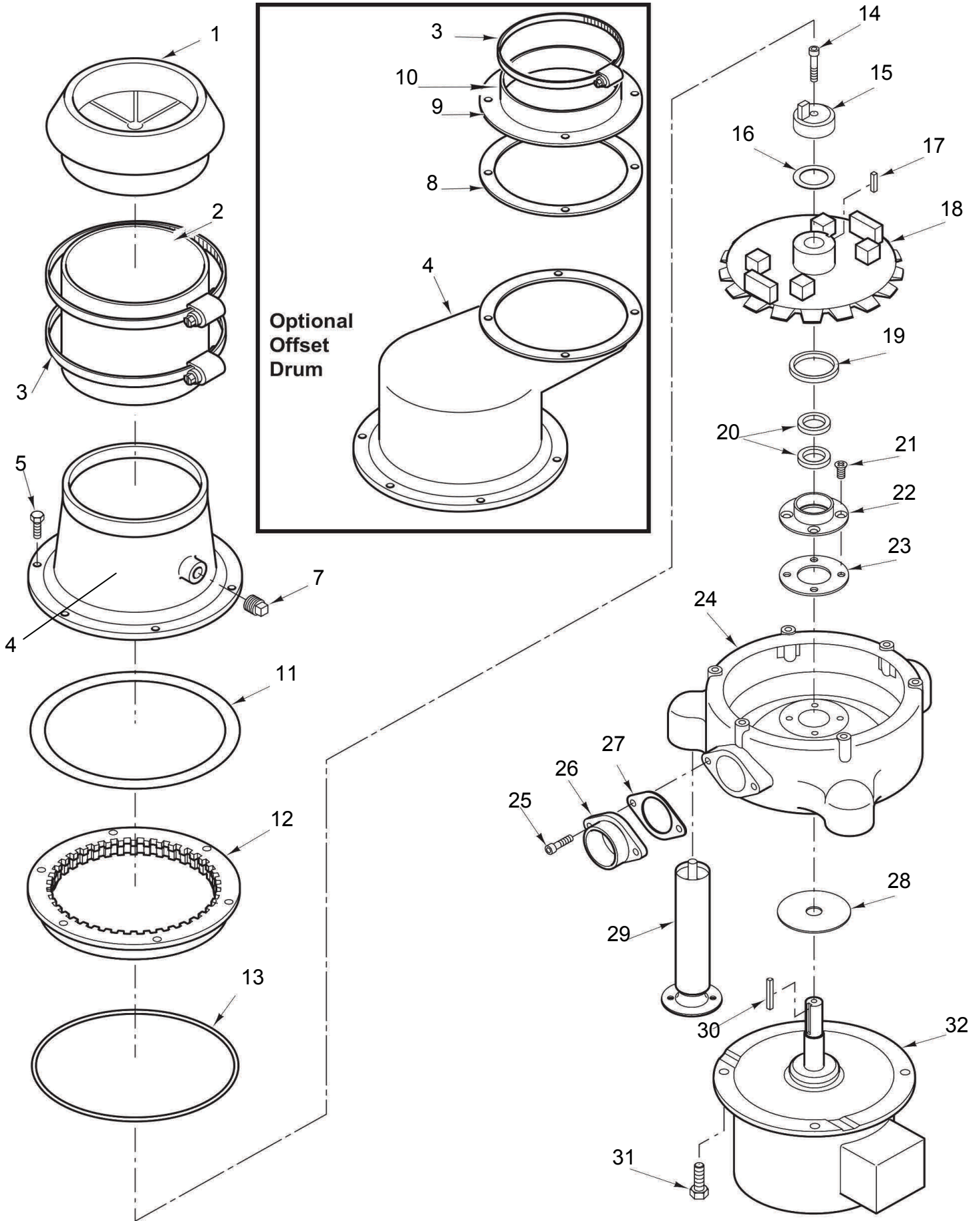

B SERIES REPLACEMENT PARTS LIST

KEY NO. PART NO. NAME: DESCRIPTION/ QTY PER MACH.

1	H-391	Silver Saver Scrapping Ring	1
2	G-554	Neoprene Connector Sleeve	1
3	A-3000	Stainless Steel Clamps	2
4	G-556	Chamber	1
	G-299	Offset Chamber	1
5	A-4100	Screw: Hxhd 3/8-24x1-3/4	6
6	08-BC-312	Washer: Lock Split 5/16	6
7	10-5-27.	Pipe Plug: 1/2"	1
8	D-158	Gasket: Offset Adaptor	1
9	D-162	Offset Adaptor Plate	1
10	D-056	Neoprene Offset Adaptor	1
11	B-500	Gasket: Sizing Ring	1
12	D-1272	Sizing Ring	1
13	B-011	10" Buna Sizing Ring "O" Ring	1
14	A-4200	Screw: Center Breaker	1
15	A-1288	Center Breaker (includes item 19)	1
16	A-1022	Gasket: Center Breaker	1
17	A-4201	Roll Pin	1
18	D-1287N	Rotor	1
19	D-1009	Lip Seal "Rotor"	1
20	A-1011	Lip Seal "Motor Shaft"	2
21	A-4202	Screw: Seal Housing	4
22	D-1008	Seal Housing	1
23	A-019	Gasket: Seal Housing	1
24	G-247	Bowl	1
25	A-4120	Screw: 7/16-20x1 S.H.C.S.	2
26	A-159	Discharge Flange	1
27	A-161	Gasket: Discharge Flange	1
28	A-016	Slinger " Motor Shaft"	1
29	09-BC-927	Leg Assy w/Foot: 2" X 9-5/8", SS	3
30	A-1185	Key	1
31	A-2213	Screw: Motor Mounting	4

KEY NO. PART NO. NAME: DESCRIPTION/ QTY PER MACH.

MOTOR OPTIONS

32	P-0335060	Motor: 3HP/3PH/50 & 60HZ	1
	P-0535060	Motor: 5HP/3PH/50 & 60HZ	1
	02-ABC-723	Motor: 7.5 HP/3PH/60HZ	1
	02-ABC-103	Motor: 10 HP/3PH/60HZ	1

NOT SHOWN

02-BC-402	Bearing: #207 UPPER	1
02-BC-401	Bearing: #206 LOWER	1
B-SGK-NS	Seal and Gasket Kit (Includes 13,18,21,(2)22,25,29, Grease)	1
B-CRK-NS	Complete Renewal Kit (Includes (6)7,13,14,16,17,20,21,(2)22,25,29,30, Grease)	1